

# Advanced Surface Modeling

## for SolidWorks

**Rhinoceros**<sup>®</sup>  
NURBS modeling for Windows

## Advanced Surface Modeling

With Rhino you can enhance the modeling features of SolidWorks in several important ways. You can:

- Create advanced, free-form surfaces

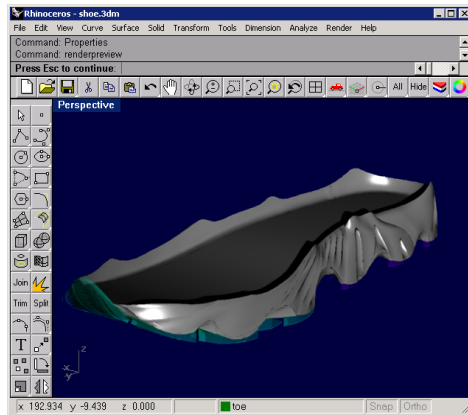

*Free-form surface.*

- Fix IGES files

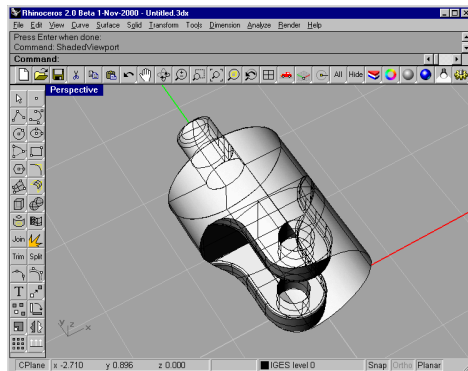

*Badly trimmed re IGES file.*

- Translate 3-D data between applications
- Edit 3-D data from diverse sources

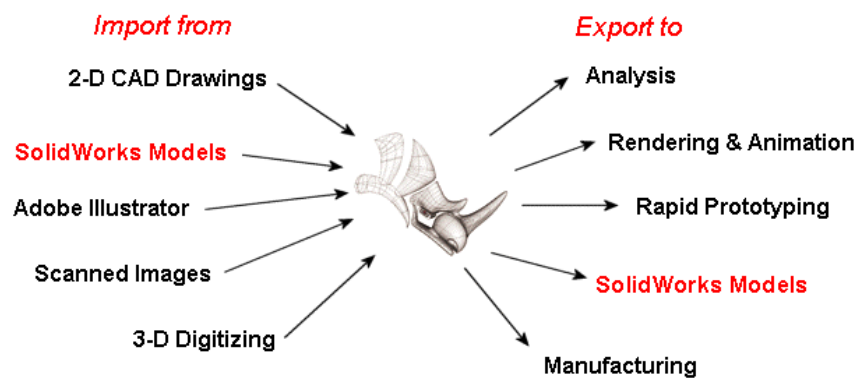

## Create Advanced Free-form Surfaces

Rhino can be used to create very accurate, free-form surface and solid models for import into SolidWorks. These models can be used as body features, as reference geometry, or as trimming surfaces.

Modeling in Rhino is different from modeling in SolidWorks and other parametric, feature-based modelers. In SolidWorks, you start with a sketch or body feature and then add features to create a command history tree. Rhino does not maintain a command history tree and has no parametric features. This frees you to work directly with solids, curves, and advanced surfaces without regard for command history or embedded sketches. Curves are used to make surfaces. Surfaces are created, trimmed, matched, evaluated, and if desired, joined into open or closed polysurfaces. Rhino supports a host of curve and surface editing tools including Boolean operations on both open and closed polysurfaces.

A closed polysurface defines a volume and can be exported as an IGES, STEP, ACIS (.sat), or Parasolid (.x\_t) files and imported into SolidWorks as a body feature.

Surfaces and open polysurfaces can also be imported into SolidWorks and thickened into body features or used to trim solids.

### Cross-Trainer Shoe Midsole

This cross-trainer midsole was modeled in Rhino. The surfaces were joined and the resulting closed polysurfaces were exported as solids as ACIS (.sat) files. They were then opened in SolidWorks as a body features.

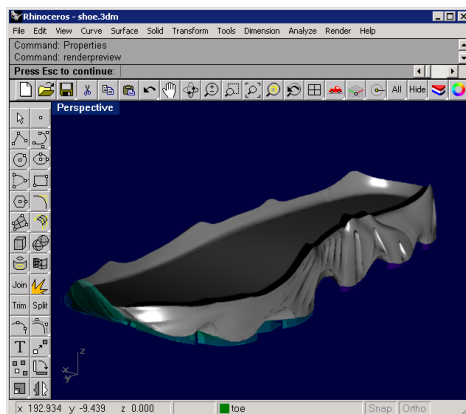

*Midsole in Rhino.*

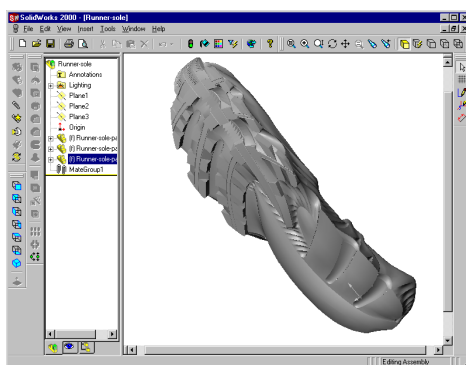

*Midsole Assembly in SolidWorks.*

## Automobile Fender

The following car fender was designed and built in Rhino. In this example the main body of the fender and the lip are to be joined with a special surface between them. This surface must have curvature (G2) continuity with the adjacent surfaces to avoid visual seams in reflections. Rhino features high-end, feature-rich, surface modeling and evaluation tools, including position, tangency, and curvature matching as shown in the following example.

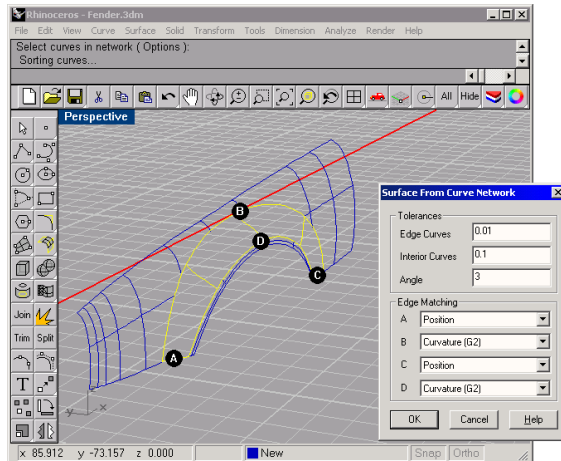

*This surface is created from a curve network.*

The NetworkSrf command is used in this case. The edges of the adjacent surfaces and previously drawn profile curves are selected as input for the command. The profile curves indicate the desired surface shape to the command. The surface edges labeled B and D have been designated for curvature (G2) matching. G2 curvature indicates the second derivative of the surface curves is equal at those edges. This ensures that there will be no visible seam in reflections on this fender.

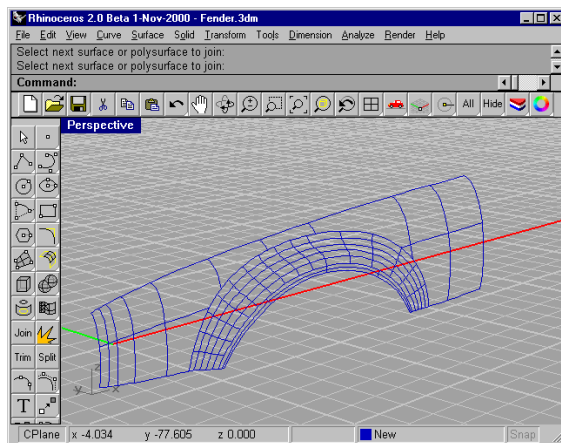

*The resulting surface.*

The following images illustrate a few of several surface quality analysis tools in Rhino. Notice the smooth transition from one surface into the next without visible line breaks in the reflection. This indicates G2 curvature continuity.

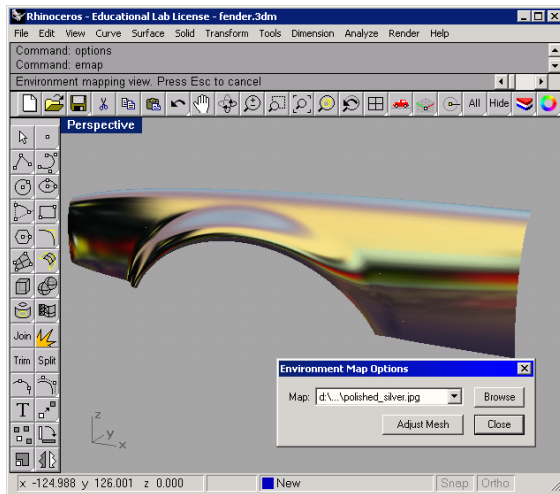

*Environment mapping used for surface analysis.*

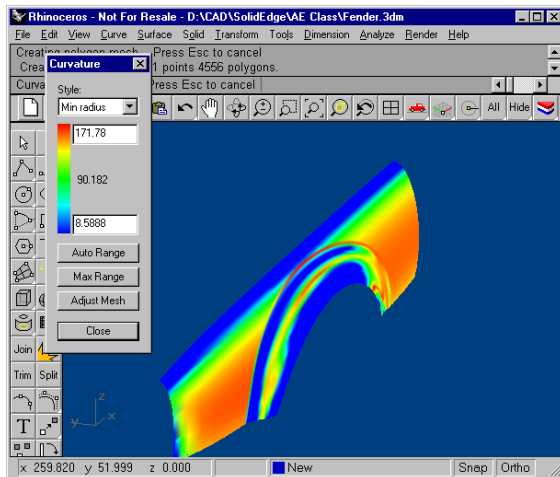

*Curvature analysis shows the curvature values of the surface in color.*

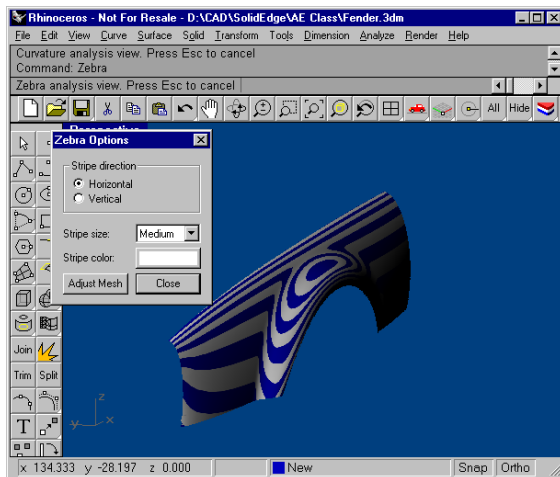

*Zebra analysis shows the continuity of the surfaces.*

The special G2 surface continuity created in Rhino is preserved into SolidWorks through IGES, STEP, Parasolid, and ACIS import. The imported open polysurface is shown below after it was thickened into a SolidWorks body feature.

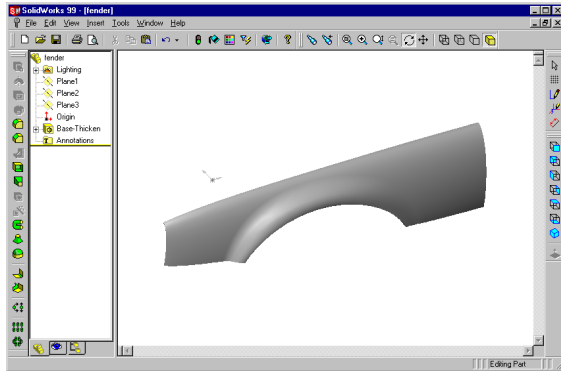

*SolidWorks base feature.*

### Trimming SolidWorks Solids with Rhino Surfaces

One powerful use of Rhino with SolidWorks is to use Rhino to make a required complicated surface and use it to trim a solid body in SolidWorks. This can be done without disturbing the command history in SolidWorks.

The steps are:

1. Export a reference part from SolidWorks.
2. In Rhino use the reference part to model a free-form surface.
3. Export the part from Rhino as an IGES or ACIS file.
4. Import the surface into SolidWorks and trim the feature with it.
5. Modify the Rhino surface and re-import it into SolidWorks.

### Terrain Model

In the following example, a Rhino surface will be created and used to trim a SolidWorks body. We will use ACIS or IGES file export from Rhino.

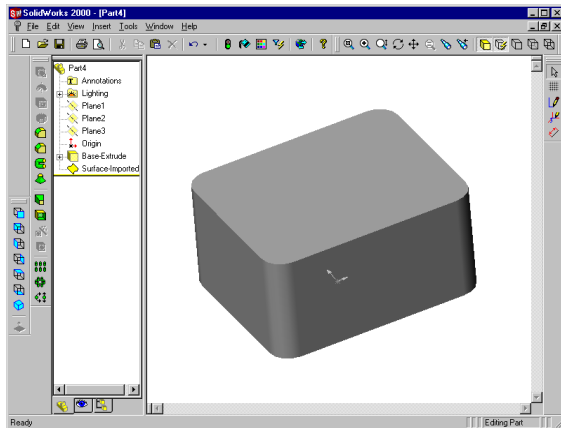

*A simple extrusion in SolidWorks.*

Save this as an IGES file, and open it in Rhino to use as reference surfaces.

By using the IGES data from SolidWorks, the new surface can be made in Rhino sized and positioned correctly so it will fit as a replacement surface in SolidWorks.

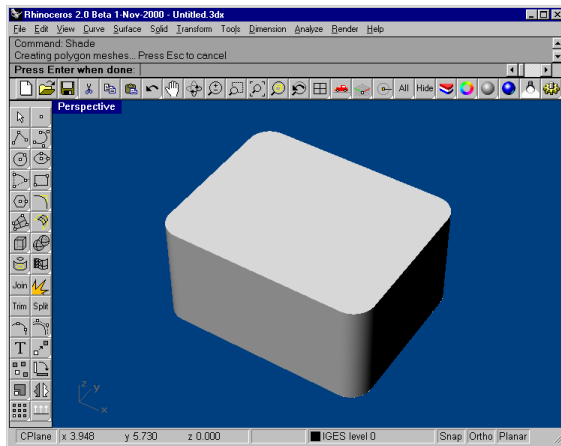

*The extruded surface in Rhino.*

Curves are used in Rhino to create a free-form surface matching the extruded surface from SolidWorks.

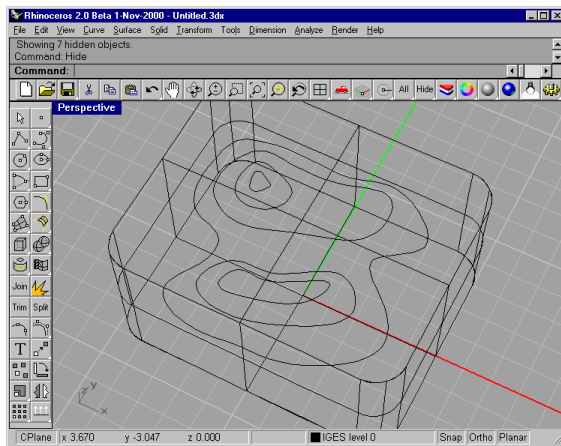

*Curves for making an organic free-form surface.*

The Patch command drapes a surface over the contour curves.

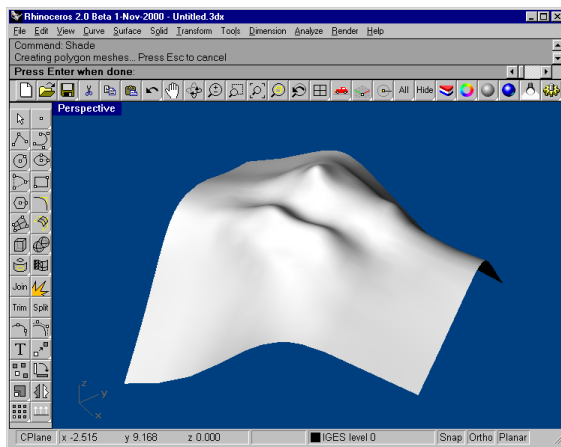

*The shaded surface.*

Export the new surface as an ACIS file and import it into SolidWorks as a surface.

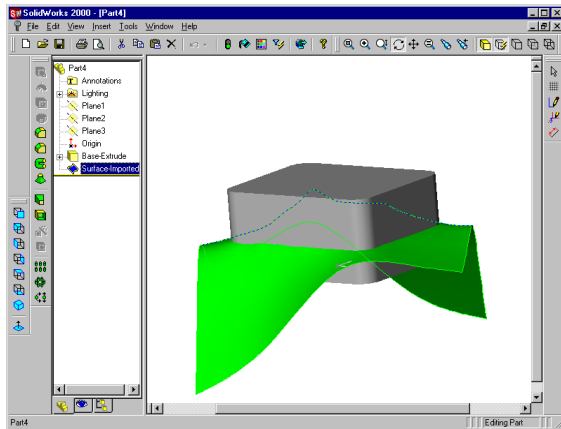

*The imported surface ready to be used as a cutting face.*

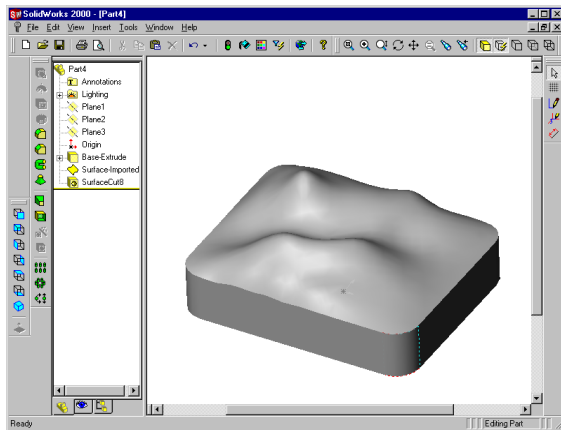

*The trimmed base feature.*

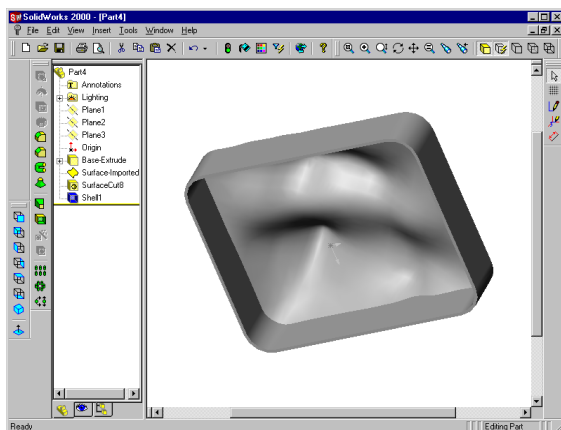

*The shelled composite body shown from the underside.*

Now the cutting surface is modified in Rhino, the ACIS (.sat) file is replaced and the link to the SolidWorks model is updated without disturbing the command history that created the shelled solid.

Select some control points and pull them around to change the shape of the surface.

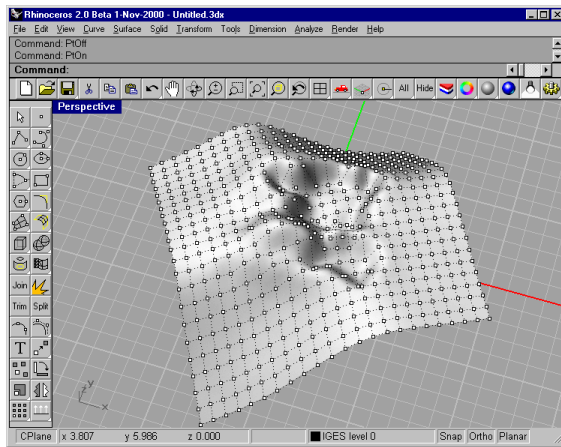

*Editing the surface shape.*

Export the surface as an IGES file this time. Then edit the definition of the imported surface in SolidWorks. Select the modified IGES file this time. The modified imported surface is read in and the shell feature is recalculated automatically.

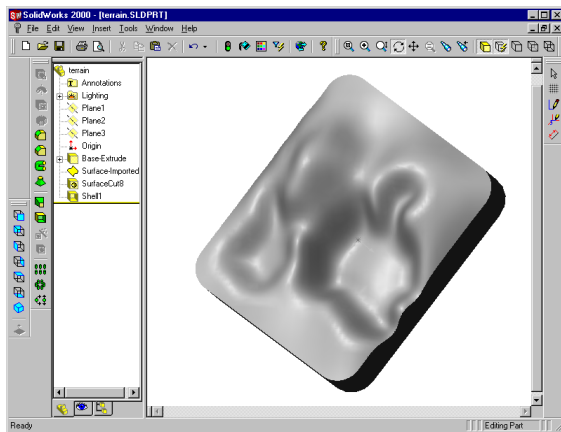

*The new surface in SolidWorks.*

The shell command history was not modified.

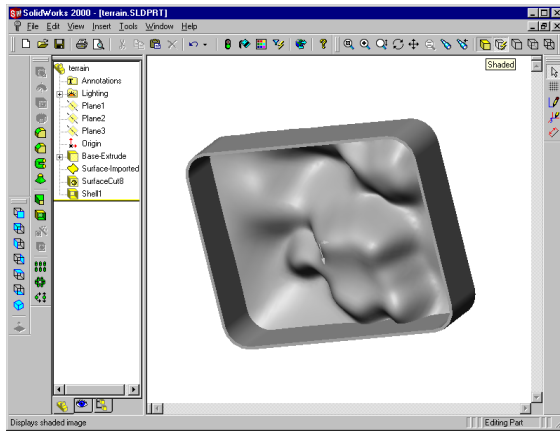

*The new surface from below showing the shell feature intact.*

### Modify Existing SolidWorks Parts

Another approach is to completely replace a part with one revised in Rhino. The steps are:

1. Export the part from SolidWorks as IGES. Note: Make sure your IGES export options match your modeling units and precision settings.
2. Open it in Rhino preserving size and location information.
3. Harvest curves or surfaces from the original part.
4. Design and model a new replacement part.
5. Import the replacement part back into SolidWorks.

This part is the knob from the SolidWorks Handle Tutorial. The knob was imported into Rhino as an IGES file. The basic shapes were modified to create a more organic shaped knob and then imported back to SolidWorks as a Parasolid base feature.

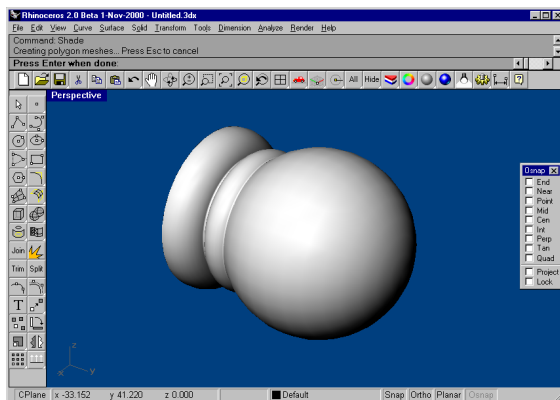

*IGES file imported into Rhino.*

Next we will detach and remove the external surfaces from the original knob.

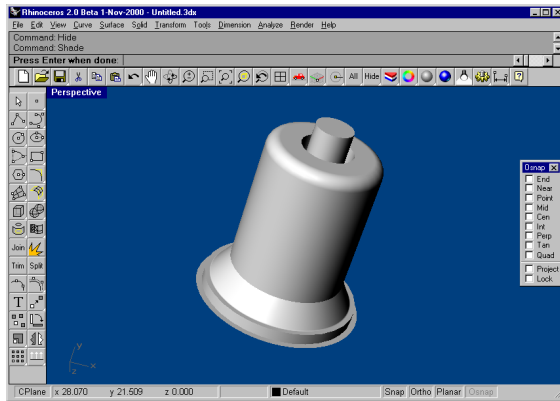

*Knob with exterior surfaces removed.*

The next task is to build a profile curve we will use to revolve a starting shape.

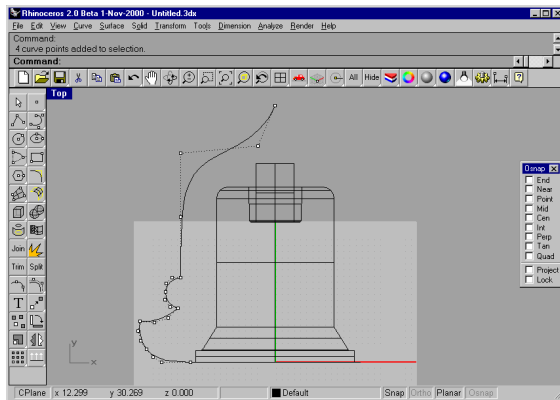

*New profile curve shown with control points turned on.*

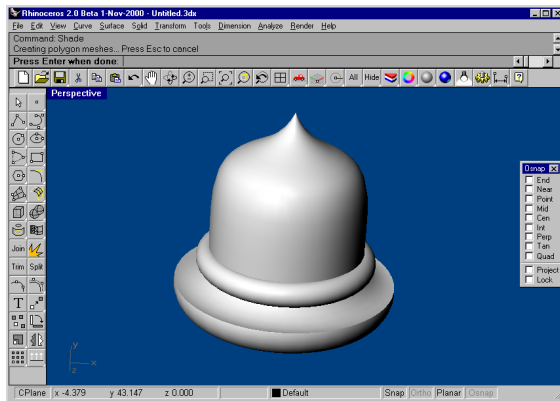

*Basic revolved surface.*

The next step will be to rebuild the surface to add additional control points for further editing. For the sake of brevity, the next steps will involve 2-D scaling of selected control points and then twisting them to achieve the desired shape.

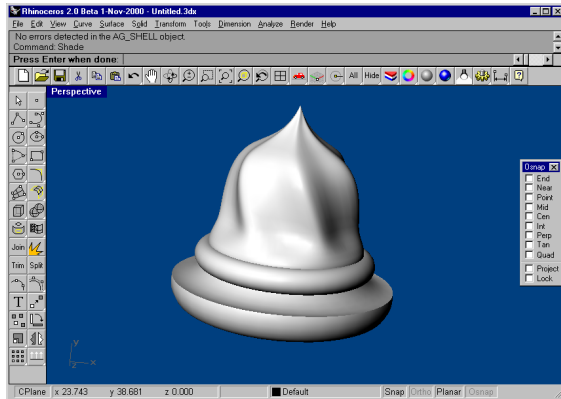

*Final revised knob in Rhino.*

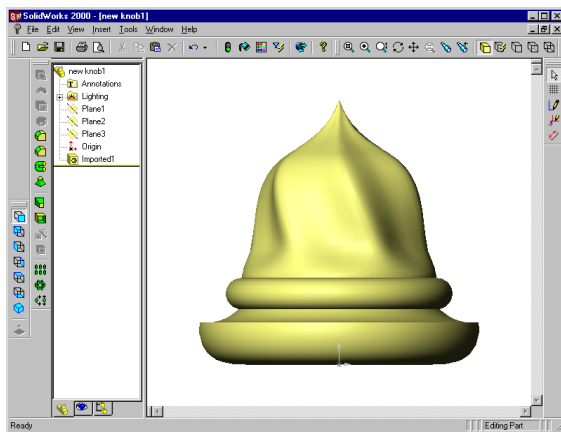

*New knob part file in SolidWorks.*

If the part was used in an assembly and constrained to position it, the re-designed knob will take the place of the old part.

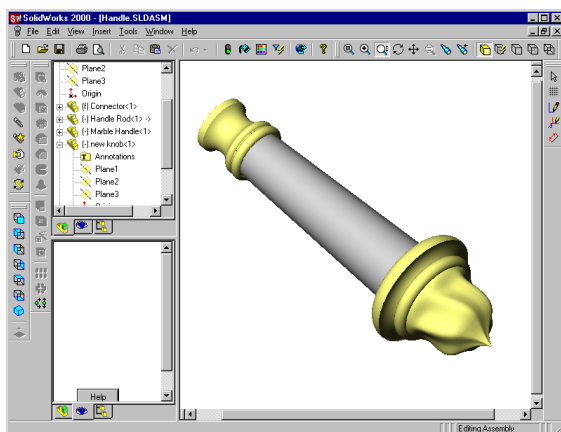

*Assembly shown with new revised knob.*

## Fixing IGES Files

One powerful use of Rhino's file translation ability is to clean up poorly written IGES files. You may have received IGES files from your clients or suppliers that do not read properly into SolidWorks. Often this is the result of an improperly formatted IGES file, missing or duplicate surfaces, gaps or overlaps, or may contain bad surface trimming information. Rhino has the basic tools needed to overcome all of these problems. Depending on the number of problems and the size of the IGES file, this can be a very time-consuming process.

Since Rhino does not require that the IGES data consist of a closed solid, it will read in as much valid information from the model as it can, skipping corrupt objects but reading all the points, curves, and surfaces. Rhino will often read the file and fix the problems automatically. All you have to do then is save it as IGES or ACIS and read it into SolidWorks. If the repair isn't automatic, you can then replace missing surfaces, fix bad trims, fix surface discontinuities, and export a solid model for SolidWorks. Generally, you can salvage most of the data in the IGES file. Sometimes, the problems are so extreme that remodeling is the best fix. Even in this case, Rhino contains the tools to harvest isoparms, sections, and edge curves that can be used to easily preserve design intent when remodeling.

The following model would not import into SolidWorks because the large angled cylinder was not properly trimmed when it was exported to the IGES file.

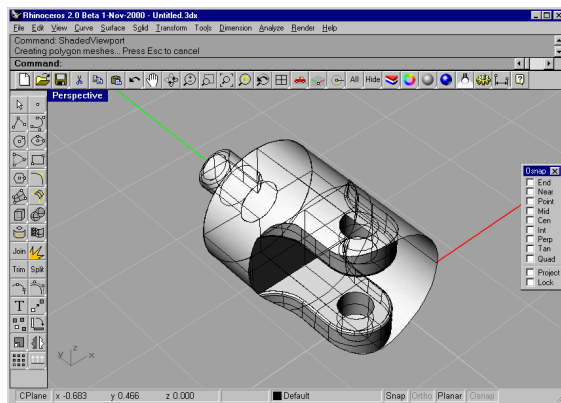

*Badly trimmed IGES file.*

Rhino read the file, with no loss of data, but the trim was not automatically fixed.

In Rhino the cylinder was then trimmed and joined to the rest of the part. After exporting the part as an ACIS file, it read into SolidWorks.

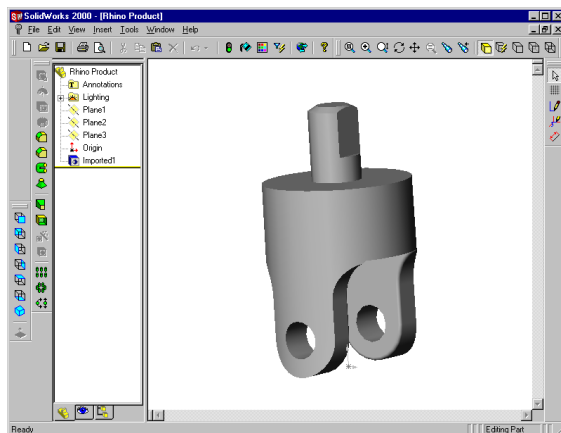

*Repaired part successfully imported as a solid in SolidWorks.*

## General Strategy

The general strategy in repairing IGES files will vary greatly depending on the individual file. Over time you will discover patterns of problems from individual applications.

### Start with a clean file

The old adage, an ounce of prevention is worth a pound of cure, applies IGES file transfers too. When possible, spending a little time in the originating application to export a "clean" file will save a great deal of clean up work later. Unfortunately, this is not always an option. Two common creators of IGES data are CATIA and Pro/Engineer. The following procedures and settings will minimize the problems associated with importing IGES data from these applications.

## CATIA

Export from CATIA by preparing the model, mainly to improve the trimming curves. Here are the procedures one of our customers uses in CATIA to minimize their downstream clean up tasks.

- 1 To prepare the model for transfer, work with the volume:  
SOLID + EXTRACT + VOLUME
- 2 Clean the model of the solid and all extraneous geometry:  
KEEP + SELECT + GEOMETRY + ELEMENT and select the "VOLUME"
- 3 Recalculate the boundary curves:  
Bring the old boundaries out of NO-SHOW:  
ERASE + NOSHOW // YES:SWAP. Key in \*SPC - \*SUR and YES:SWAP to return.
- 4 ERASE and key in \*SPC - \*VOL
- 5 CURVE1 + BOUNDARY and key in \*FAC
- 6 Run /CLN to check for errors  
The model is now ready to transfer.

## Pro/Engineer

To optimize export of Pro/E files into Rhino:

- 1 Use these settings in the Pro/E "config.pro" file or save them as a "rhino.pro" file and read it in before exporting.  
IGES\_OUT\_ALL\_SRFS\_AS 128  
IGES\_OUT\_SPL\_CRVS\_AS\_126 YES  
IGES\_OUT\_SPL\_SRFS\_AS\_128 YES  
IGES\_OUT\_TRIM\_XYZ YES  
IGES\_OUT\_MIL\_D\_28000 NO  
IGES\_OUT\_TRM\_SRFS\_AS\_143 NO  
IGES\_OUT\_TRIM\_CURVE\_DEVIATION DEFAULT  
INTF\_OUT\_BLANKED\_ENTITIES NO  
INTF3D\_OUT\_EXTEND\_SURFACE YES  
INTF3D\_OUT\_FORCE\_SURF\_NORMALS YES  
  
IGES\_IN\_106\_F2\_AS\_SPLINE NO  
IGES\_IN\_DWG\_LINE\_FONT YES  
IGES\_IN\_DWG\_PNT\_ENT YES  
IGES\_IN\_DWG\_COLOR YES  
FIX\_BOUNDARIES\_ON\_IMPORT YES
- 2 **Hide** or delete extra data

Use the **SeIDup** command to find duplicate entities and move the extra ones to a "duplicate" layer or delete them. You may need them later.

**3 Hide curves and points**

Use **SeISrf** to select all the surfaces, **Invert** the selection, and move them to another layer. This will leave only surfaces on the screen.

**4 Check for bad surfaces**

The **Check** and **SeIBadObjects** commands will determine if some of the surfaces in the model have problems in their data structures. Move these surfaces to a "bad surfaces" layer for later clean up.

**5 Shade and visually inspect the model**

Does it look like you expected it would? Are there obviously missing surfaces? Do surfaces extend beyond where they should? The trimming curves needed to fix them may be on the "duplicate" layer.

**6 Look at the absolute modeling tolerance in file properties**

Is it reasonable? Free-form surface modeling requires an intelligent compromise in modeling tolerance. NURBS curves are chains of polynomial expression segments joined by knots, that carry continuity information between the segments. These segments are fitted to neighboring curves within the specified modeling tolerance. The tighter the tolerance, the more complex these curves become and system performance suffers. There is no point in calculating high density curve fitting to tolerance values that are not supported by your downstream manufacturing processes.

**7 Join the surfaces**

When joining, edges are tagged as joined if they fit within the specified modeling tolerance. If they are outside the tolerance, they are not joined. Joining does not alter the geometry. It only tags the edges as being close enough to be treated as coincidental. Look at the results on the command line. Did you get as many polysurfaces as you thought you would? Sometimes there are double surfaces after importing an IGES file. Usually, one will be complete and the second one will be missing interior trims. When the **join** happens, you have no control over which of the two surfaces it will select. If you suspect this has occurred, try joining two naked edges. If there is no near by naked edge where one should be, **undo** the join, and select for duplicate surfaces. Delete the less complete surfaces and try the **join** again.

**8 Check for naked edges**

Naked edges are surface edges that don't connect to anything. During the join process, they were farther apart than the specified modeling tolerance. This may be from sloppy initial modeling, a misleading tolerance setting in the imported IGES file, or duplicate surfaces. If there are too many naked edges showing when you run the **ShowNakedEdges** command, consider undoing the join and relaxing the absolute tolerance. It is likely that the original modeling was done to a more relaxed tolerance and the exporting to a higher setting.

**Note: You can not improve the tolerance fitting between surfaces without substantial remodeling.**

**9 Join naked edges or remodel**

The joining of naked edges can be a mixed blessing. It is a trade off and may cause problems down-stream. If your reason for joining the edges is for later import into SolidWorks as a solid, or a meshing operation like making an STL file, using the **JoinEdge** command will not generally cause any problems. If you will be cutting sections and most other "curve harvesting" operations, the sections will have gaps as they cross edges that were joined outside of tolerance. The gap to be spanned is displayed prior to joining. If the gap is sell than twice of your tolerance setting, you can proceed without worry. If the gap is too wide, consider editing or rebuilding the surfaces to reduce the gap. **Join** and **JoinEdge** do not alter the surface geometry. They only tag edges as accepted as being coincident within the specified or override tolerance.

#### 10 Repair the bad surfaces

It's best to repair one bad surface at a time, and **join** them into the polysurface as you go. In order of least destructive method to most radical, the problems that caused them to fail **check** can be repaired by the following methods:

- Rebuild edges
- Detach trim curves and re-trim
- Rebuild surfaces
- Replace surfaces - harvesting edges from surrounding surfaces, cutting sections through bad surfaces and building replacement surfaces from the collected curves.

If a surface fails check reporting that a *tedge* (trim edge) is not G1, this minor error can be ignored or the multiple span surface can be split on the knots.

#### 11 Check for bad objects

Sometimes joining surfaces that pass check can result in a polysurface that fails check. Generally this is caused by tiny segments in the edge or trimming curves that are shorter than the modeling tolerance. Subtract the adjoining surfaces, check them, edit the boundary curves to eliminate these tiny segments, and join them back in. You are finished when you have a closed polysurface that passes **Check** and has no naked edges. As you are joining and fixing surfaces, it is generally a good idea to run **Check** from time to time as you work.

#### 12 Export

Now that the IGES file has been cleaned up and repaired, you can export it as IGES, Parasolid, or STEP for import into SolidWorks. Parasolid is the preferred format for associativity but there are situations where the other file formats are useful. The Parasolid "universe" is defined as a region centered around 0,0,0 that extends 1000 meters in three axes, with 10 x e6 precision. All Parasolid calculations are converted to meters and must fit within this "universe". If your model is positioned in space and is sized such that it will fall outside this boundary, you will need to move it closer to the origin to avoid translations problems.

## Translate 3-D Data Between Applications

At the simplest level, Rhino can be used as a powerful file translator. You can accurately share 3-D models with other applications for rendering, animation, drafting, engineering, analysis, and manufacturing.

Supported file formats include:

DWG/DXF (AutoCAD 2000, 14, 13, and 12), SAT (ACIS), X\_T (Parasolid), 3DS, LWO, STL, OBJ, AI, RIB, POV, UDO, VRML, BMP, TGA, JPG, CSV (export properties and hydrostatics).

IGES (Alias, Ashlar Vellum, AutoFORM, AutoShip, Breault, CADCEUS, CAMSoft, CATIA, Cosmos, Delcam, FastSurf, FastSHIP, Integrity Ware, IronCAD, LUSAS, Maya, MAX 3.0, Mastercam, ME30, Mechanical Desktop, Microstation, NuGraf, OptiCAD, Pro/E, SDRC I-DEAS, Softimage, SolidWorks, SolidWorks, SUM 4, SURFCAM, TeKSoft, Unigraphics).

Most of the commonly used file formats are represented here, and new formats are added to Rhino as needed.

With these file formats, you can use sketches, drawings, or 3-D models from just about anywhere as a basis for your model including parts that have already been modeled in SolidWorks.

## Use a 3-D Digitizer to Collect Data

Rhino can act as an interface for Microscribe and Faro Space Arm digitizers to gather data or reverse engineer products.



*Direct support for MicroScribe and Faro Space Arm 3-D digitizers.*

## Rhino as SolidWorks Companion

Teaming Rhino as a companion application for fixing IGES files, as a file translator, as a tool for creating very accurate complex surfaces, and using data from a wide variety of diverse sources, can dramatically increase the power of SolidWorks. From the above examples, you should now have a basic understanding of how Rhino can extend the reach of SolidWorks more deeply into free-form industrial design and how it can get you out of difficult situations. For more information and to download a full functioning evaluation version, visit [www.rhino3d.com](http://www.rhino3d.com).